

TASHA 3/ DANIEL  
03. 2. 15

# Decision matrix

	Simplicity	ease of construction	looks	cost
1	7	8	6	7 = 28
2	6	7	8	7 = 28
3	8	8	<del>8</del>	8 = 32
4	4	4	5	6 = 19

1

# Marble Sorter

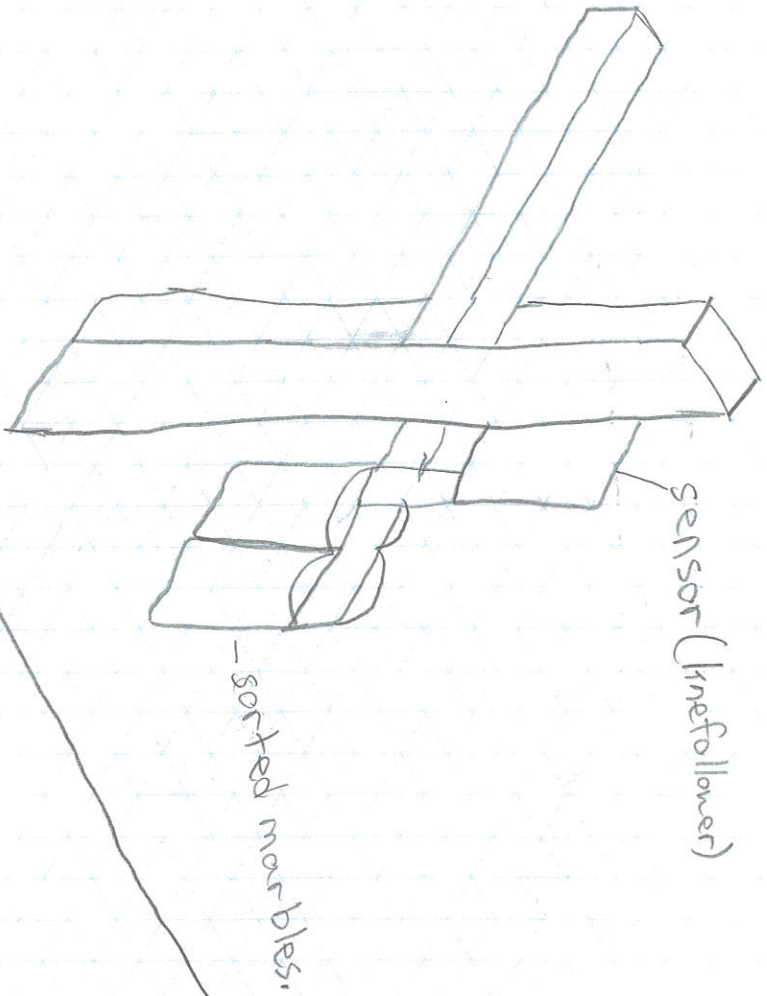

2

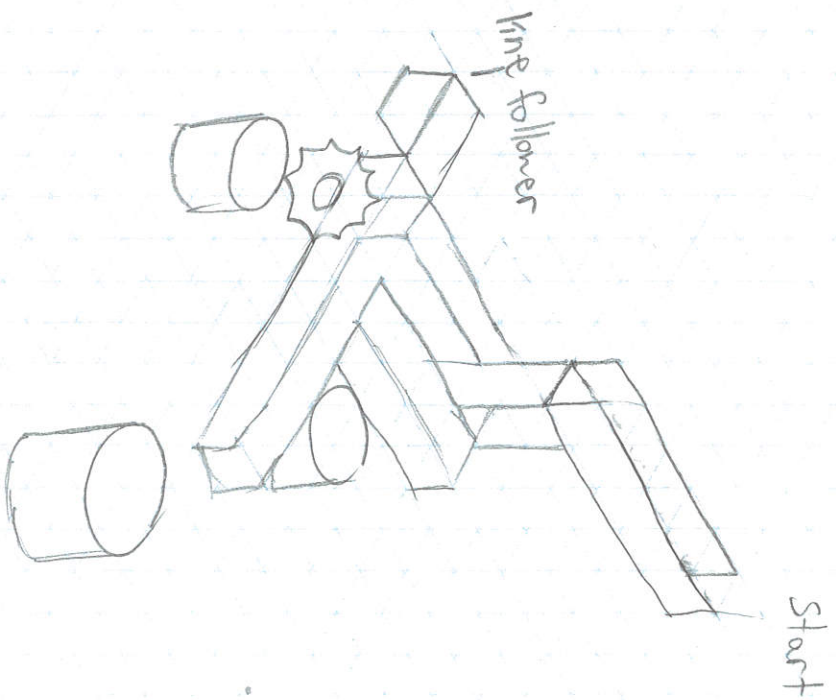

M.A. Strayson 3/2/15

3

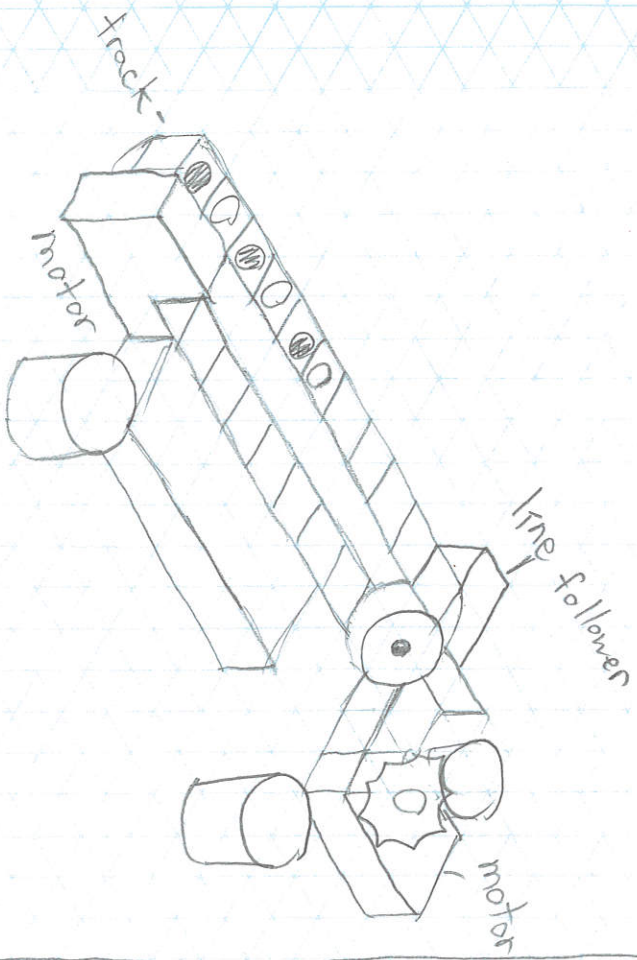

4

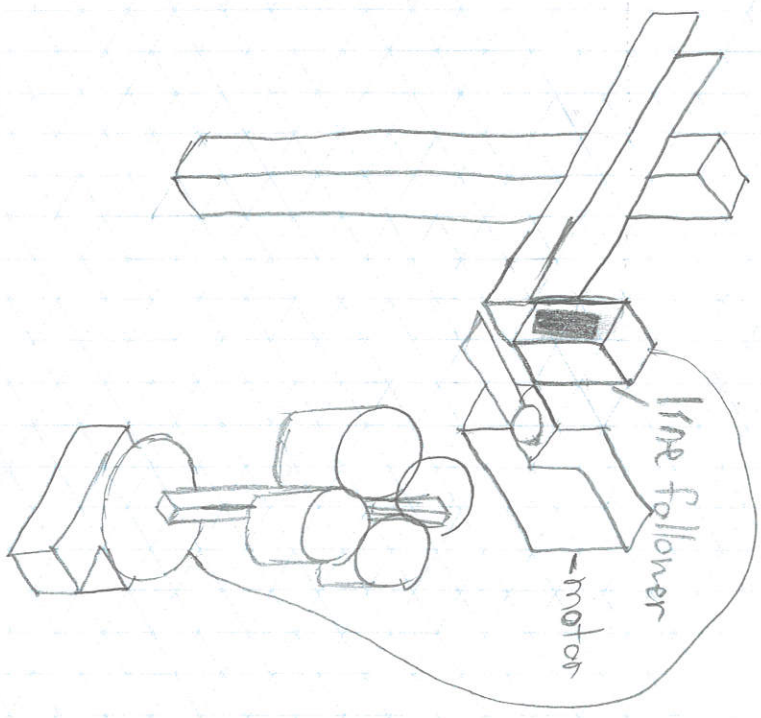

M. Du Strayson 3/2/15

# Decision Matrix

	Durability	Size	Efficiency	Easy to build	Total
1	5	8	5	8	26
2	8	4	7	6	25
3	10	3	8	5	26
4	6	5	6	7	24



1

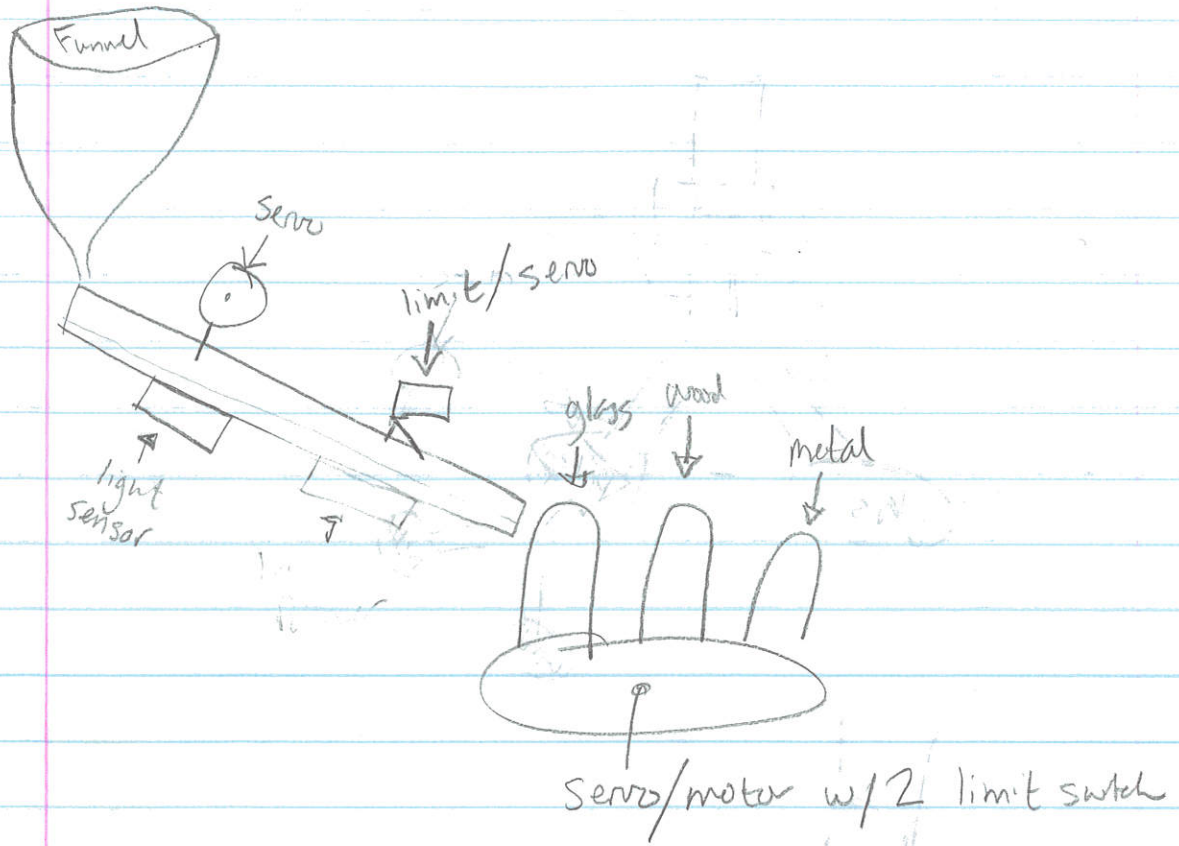

light - if less than (x)

2

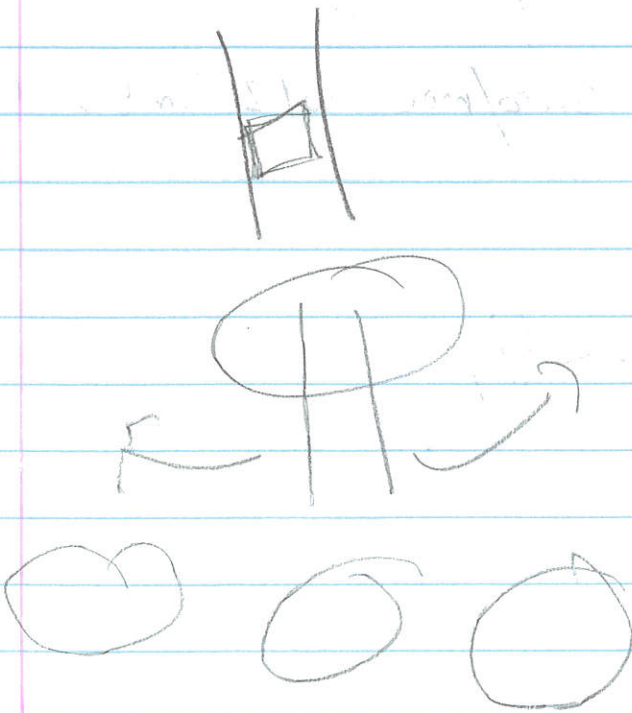
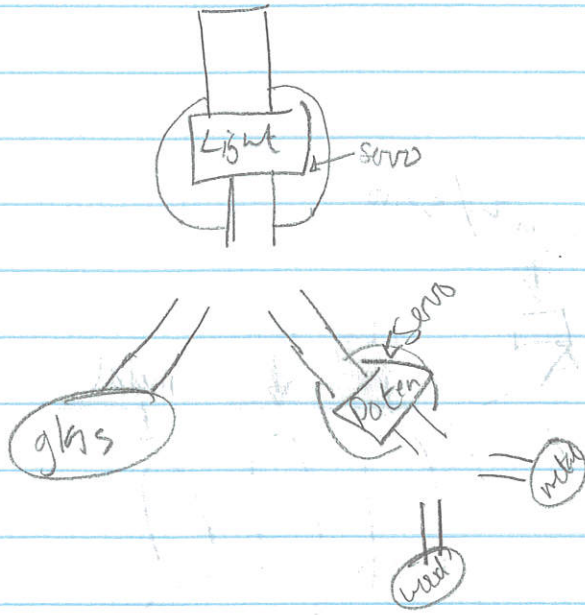

#3

Top View

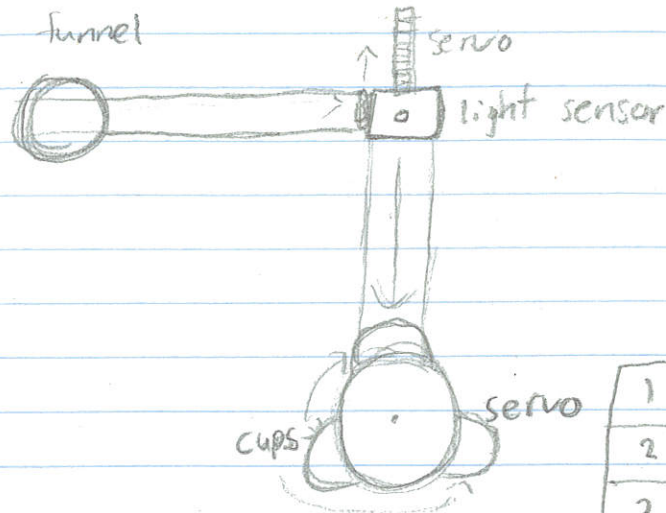

Decision Matrix

	accurate	speed	coding	buildability	
1	5	4	3	3	15
2	4	3	4	2	13
3	4	4	3	5	16
4	4	2	5	2	13

scale:  
-1-5+

#4

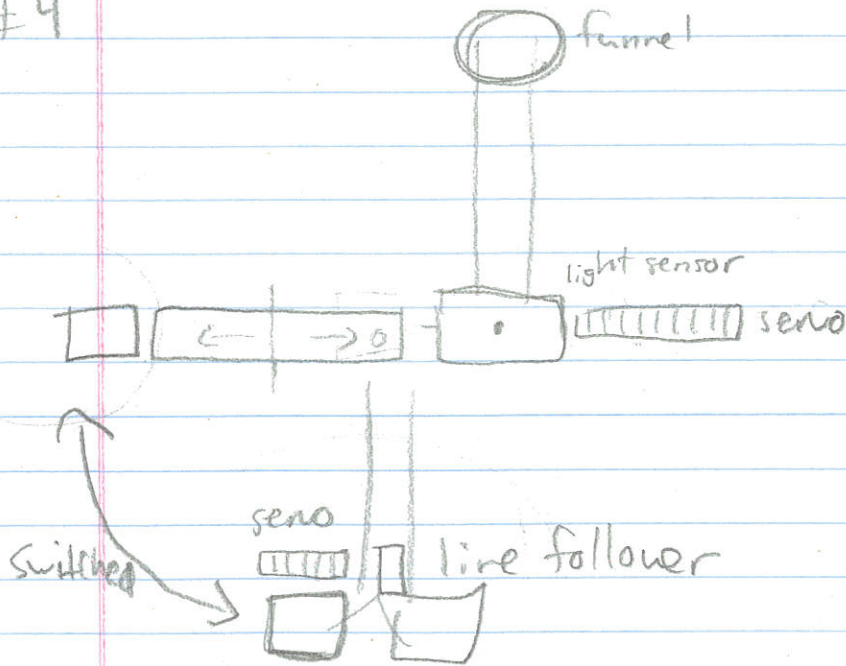

\* if light value  
 > (X) 127  
 \* if value  
 < (X) 27